

Kingbright

2007-2009

P 2-8

PHOTOCOUPLERS

P 9-10

PHOTO REFLECTIVE SENSOR & PHOTOLINK

P 11-16

PHOTO INTERRUPTERS

P 17

INFRARED RECEIVER MODULE



Part No.	Pin Configuration	Safety Standards	Features	Absolute Maximum Ratings				Electrical Characteristics				Fig.
				Isolation Voltage(AC) Viso(Vrms)	Collector Emitter Voltage VCEo(V)	CTR(%)		V(sat) (V)		Response time(μs) Typ.		
						Min.	Max.	Typ.	Max.	tr	tf	

KB814		UL NO.E225308 & VDE0884. NO.40006364	High isolation voltage AC input response	5000	35	20	300	0.1	0.2	4	3	1
KB824												2
KB834												3
KB844												4

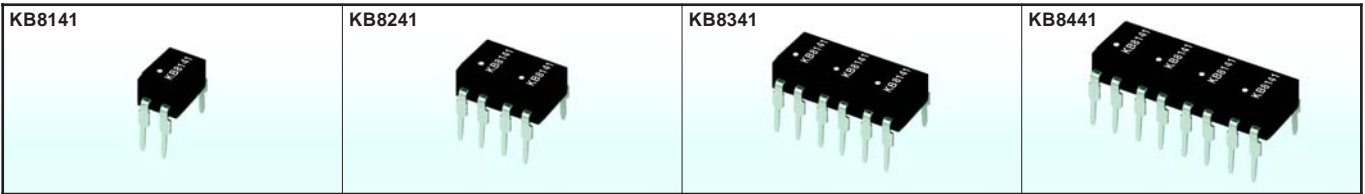

Part No.	Pin Configuration	Safety Standards	Features	Absolute Maximum Ratings				Electrical Characteristics				Fig.
				Isolation Voltage(AC) Viso(Vrms)	Collector Emitter Voltage VCEo(V)	CTR(%)		V(sat) (V)		Response time(μs) Typ.		
						Min.	Max.	Typ.	Max.	tr	tf	

KB8141		UL NO.E225308 & VDE0884. NO.40006364	High isolation voltage High sensitivity AC input response	5000	35	600	7500	0.8	1	60	53	1
KB8241												2
KB8341												3
KB8441												4

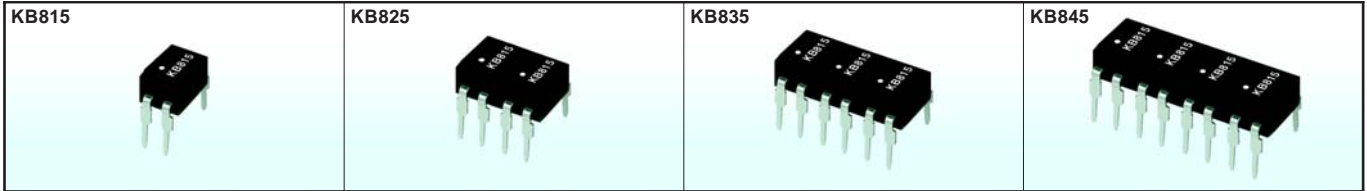

Part No.	Pin Configuration	Safety Standards	Features	Absolute Maximum Ratings				Electrical Characteristics				Fig.
				Isolation Voltage(AC) Viso(Vrms)	Collector Emitter Voltage VCEo(V)	CTR(%)		V(sat) (V)		Response time(μs) Typ.		
						Min.	Max.	Typ.	Max.	tr	tf	
KB815		UL NO.E225308 & VDE0884. NO.40006364	High isolation voltage High sensitivity	5000	35	600	7500	0.8	1	60	53	1
KB825												2
KB835												3
KB845												4

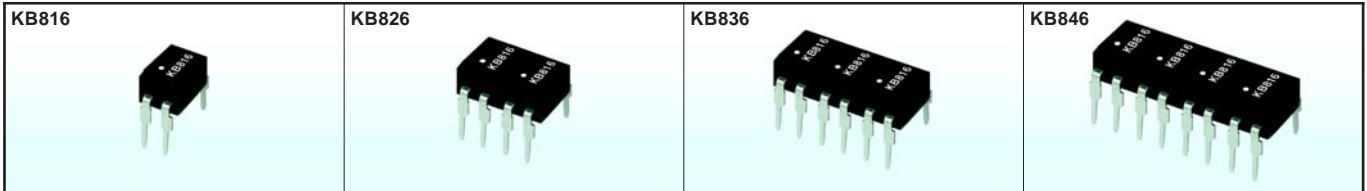

Part No.	Pin Configuration	Safety Standards	Features	Absolute Maximum Ratings				Electrical Characteristics				Fig.
				Isolation Voltage(AC) Viso(Vrms)	Collector Emitter Voltage VCEo(V)	CTR(%)		V(sat) (V)		Response time(μs) Typ.		
						Min.	Max.	Typ.	Max.	tr	tf	
KB816		UL NO.E225308 & VDE0884. NO.40006364	High isolation voltage High collector-emitter voltage	5000	70	50	600	0.1	0.2	4	3	1
KB826												2
KB836												3
KB846												4



Part No.	Pin Configuration	Safety Standards	Features	Absolute Maximum Ratings		Electrical Characteristics						Fig.
				Isolation Voltage(AC) Viso(Vrms)	Collector Emitter Voltage VCEo(V)	CTR(%)		V(sat) (V)		Response time(μs) Typ.		
						IF=5mA, VCE=5V	IF=20mA, IC=1mA	Min.	Max.	Typ.	Max.	

KB817		UL NO.E225308 & VDE0884. NO.40006364	High isolation voltage	5000	35	50	600	0.1	0.2	4	3	1
KB827												2
KB837												3
KB847												4



Part No.	Pin Configuration	Safety Standards	Features	Absolute Maximum Ratings		Electrical Characteristics						Fig.
				Isolation Voltage(AC) Viso(Vrms)	Collector Emitter Voltage VCEo(V)	CTR(%)		V(sat) (V)		Response time(μs) Typ.		
						IF=5mA, VCE=5V	IF=20mA, IC=1mA	Min.	Max.	Typ.	Max.	

KB817-B		UL NO.E225308 & VDE0884. NO.40006364	High isolation voltage SMD Type	5000	35	50	600	0.1	0.2	4	3	5
KB827-B												6
KB837-B												7
KB847-B												8

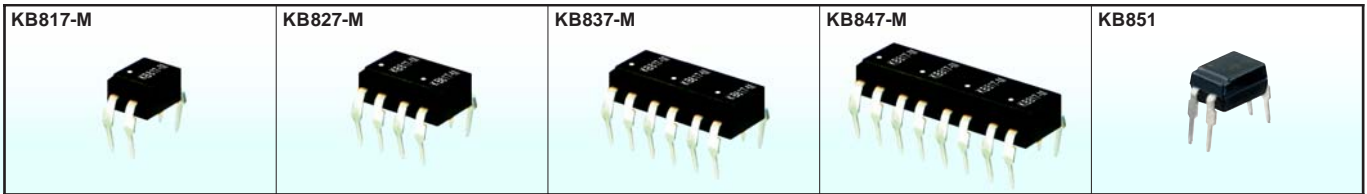



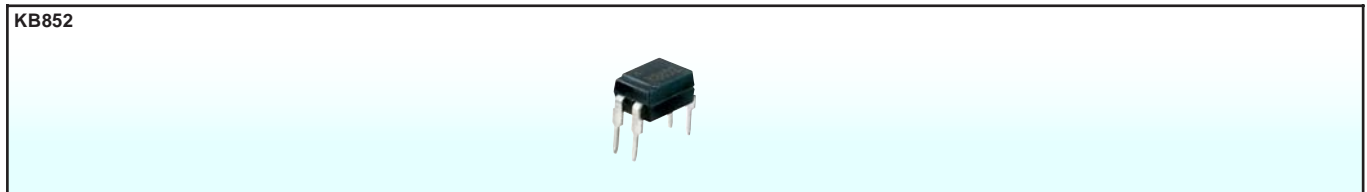

Part No.	Pin Configuration	Safety Standards	Features	Absolute Maximum Ratings		Electrical Characteristics						Fig.
				Isolation Voltage(AC) Viso(Vrms)	Collector Emitter Voltage VCE0(V)	CTR(%)		V(sat) (V)		Response time(μs) Typ.		
						IF=5mA, VCE=5V	IF=20mA, IC=1mA	Min.	Max.	Typ.	Max.	

KB817-M		UL NO.E225308 & VDE0884. NO.400063-64	High isolation voltage	5000	35	50	600	0.1	0.2	4	3	9
KB827-M												10
KB837-M												11
KB847-M												12
KB851		VDE0884. NO.400063-64	High collector-emitter Voltage	5000	350	-	-	0.1	0.3	4	3	1



Part No.	Pin Configuration	Safety Standards	Features	Absolute Maximum Ratings		Electrical Characteristics						Fig.
				Isolation Voltage(AC) Viso(Vrms)	Collector Emitter Voltage VCE0(V)	CTR(%)		V(sat) (V)		Response time(μs) Typ.		
						IF=1mA, VCE=2V	IF=20mA, IC=100mA	Min.	Max.	Typ.	Max.	

KB852		VDE0884. NO.400063-64	High collector-emitter voltage High sensitivity	5000	350	1000	15000	-	1.2	100	20	1
-------	--	-----------------------	---	------	-----	------	-------	---	-----	-----	----	---

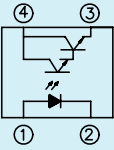
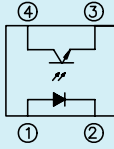
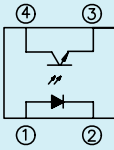
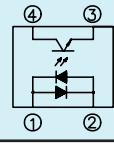
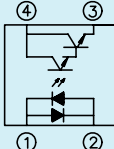
KB355NT		KB356NT		KB357NT		KB354NT		KB3541NT				
												
Part No.	Pin Configuration	Safety Standards	Features	Absolute Maximum Ratings		Electrical Characteristics						Fig.
				Isolation Voltage(AC) Viso(Vrms)	Collector Emitter Voltage VCE0(V)	CTR(%)		V(sat) (V)		Response time(μs) Typ.		
						Min.	Max.	Typ.	Max.	tr	tf	
						IF=1mA, VCE=2V	IF=20mA, IC=1mA	VCE=2V, IC=2mA, RL=100Ω				
KB355NT		UL NO.E225308 & VDE0884. NO:40017614	High current transfer ratio Small package size	3750	35	600	7500	0.8	1.0	60	53	13
Part No.	Pin Configuration	Safety Standards	Features	Absolute Maximum Ratings		Electrical Characteristics						Fig.
				Isolation Voltage(AC) Viso(Vrms)	Collector Emitter Voltage VCE0(V)	CTR(%)		V(sat) (V)		Response time(μs) Typ.		
						Min.	Max.	Typ.	Max.	tr	tf	
						IF=5mA, VCE=5V	IF=20mA, IC=1mA	VCE=2V, IC=2mA, RL=100Ω				
KB356NT		UL NO.E225308 & VDE0884. NO:40017614	High collector-emitter Voltage Small package size	3750	80	50	600	0.1	0.2	6	8	13
KB357NT		UL NO.E225308 & VDE0884. NO:40017614	Small package size	3750	35	50	600	-	0.2	4	3	13
Part No.	Pin Configuration	Safety Standards	Features	Absolute Maximum Ratings		Electrical Characteristics						Fig.
				Isolation Voltage(AC) Viso(Vrms)	Collector Emitter Voltage VCE0(V)	CTR(%)		V(sat) (V)		Response time(μs) Typ.		
						Min.	Max.	Typ.	Max.	tr	tf	
						IF=±1mA, VCE=5V	IF=±20mA, IC=1mA	VCE=2V, IC=2mA, RL=100Ω				
KB354NT		UL NO.E225308 & VDE0884. NO:40017614	AC.input response Small package size	3750	35	20	400	0.1	0.2	4	3	13
Part No.	Pin Configuration	Safety Standards	Features	Absolute Maximum Ratings		Electrical Characteristics						Fig.
				Isolation Voltage(AC) Viso(Vrms)	Collector Emitter Voltage VCE0(V)	CTR(%)		V(sat) (V)		Response time(μs) Typ.		
						Min.	Max.	Typ.	Max.	tr	tf	
						IF=±1mA, VCE=2V	IF=±20mA, IC=1mA	VCE=2V, IC=2mA, RL=100Ω				
KB3541NT		UL NO.E225308 & VDE0884. NO:40017614	AC.input response High sensitivity Small package size	3750	35	450	7400	0.8	1.0	60	53	13

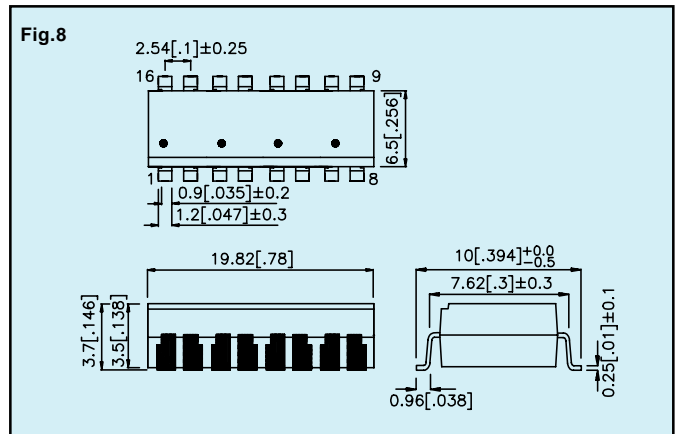
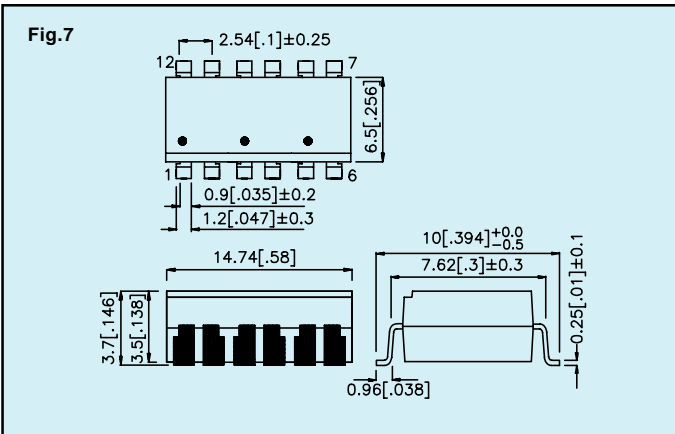
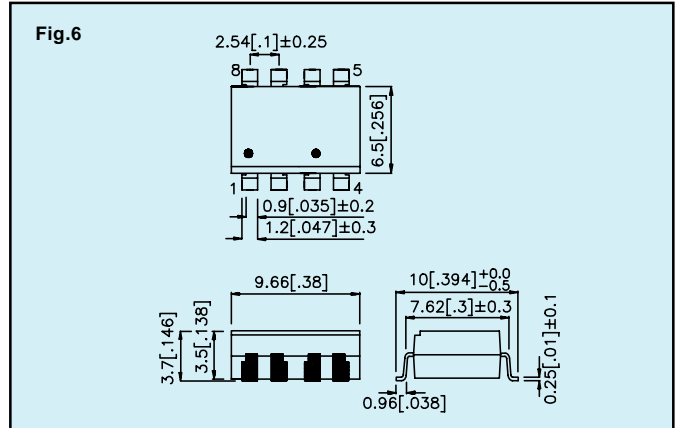
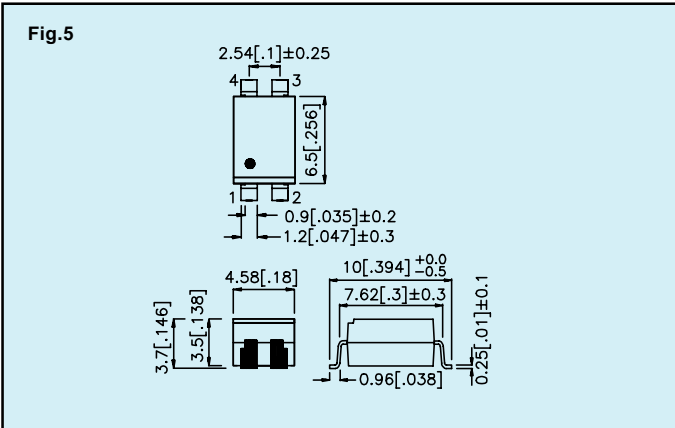
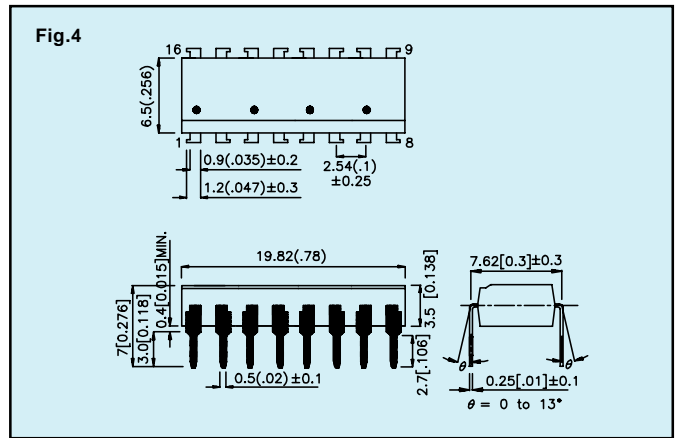
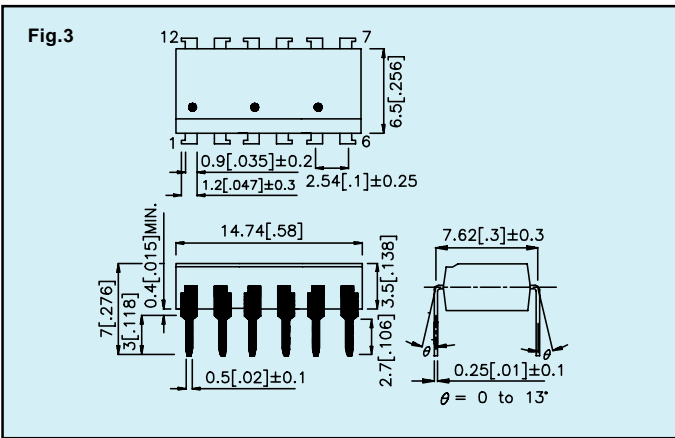
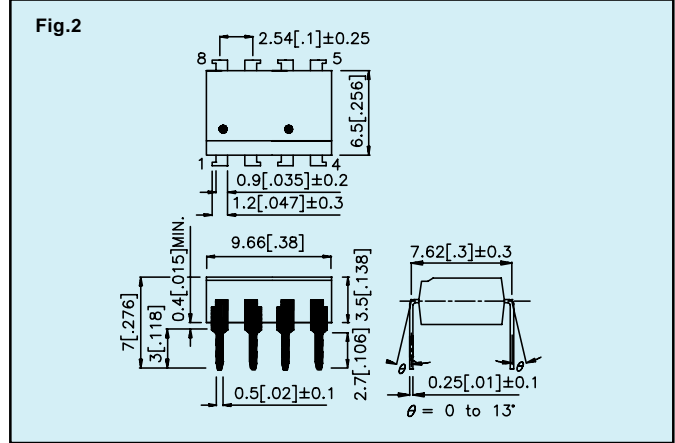
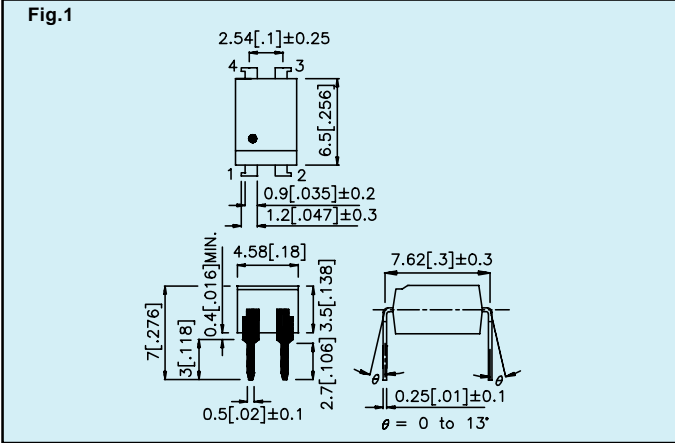

NOTES:
 1. All dimensions are in millimeters (inches).
 2. Tolerance is ±0.5mm (0.02") unless otherwise noted.

Fig.9

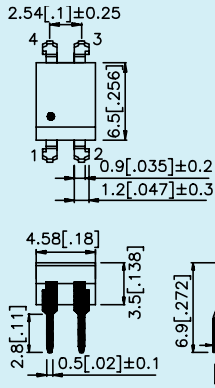

Fig.10

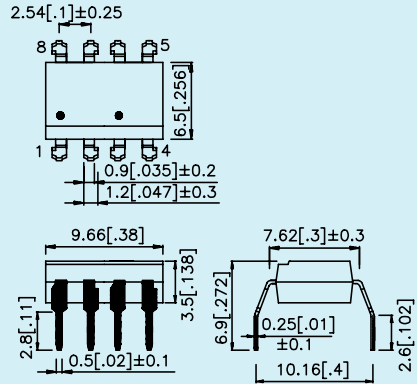

Fig.11

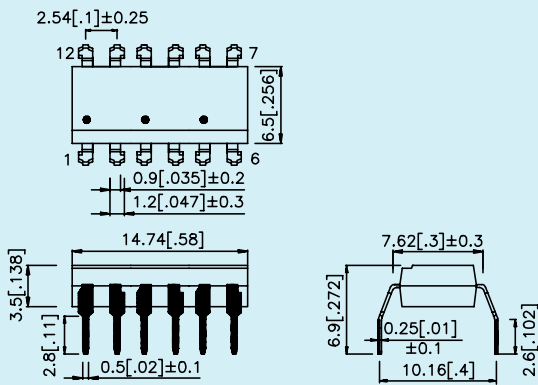

Fig.12

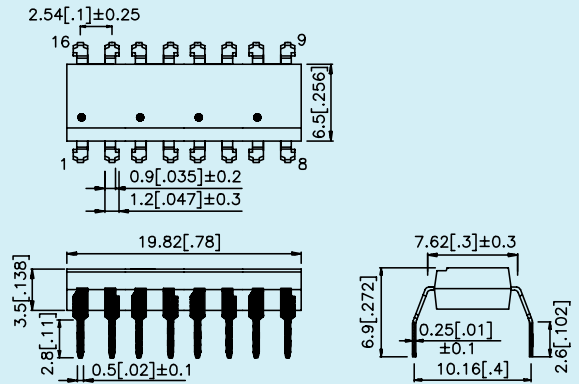
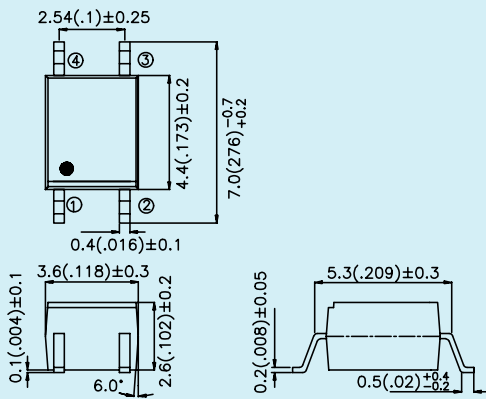
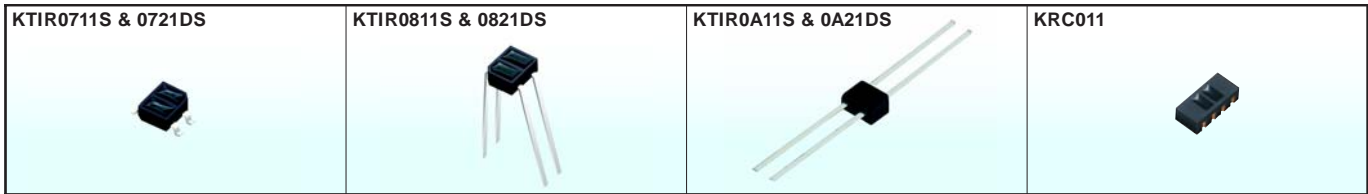

Fig.13



NOTES:

1. All dimensions are in millimeters(inches).
2. Tolerance is ±0.5mm(0.02") unless otherwise noted.



Part No.	Pin Configuration	Material	λP (nm)	I_C (μA)			$V_{CE(SAT)}$			Rise Time (μs) Typ.	Fall Time (μs) Typ.	Fig.
				$V_{CE}=2V, I_F=4mA$			IF(mA)	IC(mA)	Max.(V)			
				Min.	Typ.	Max.						

KTIR0711S		GaAs/SiC	940	10	-	400	-	-	-	20	20	1
KTIR0721DS		GaAs/SiC	940	-	3000	-	-	-	-	80	70	
KTIR0811S		GaAs/SiC	940	10	-	400	-	-	-	20	20	2
KTIR0821DS		GaAs/SiC	940	-	3000	-	-	-	-	80	70	
KTIR0A11S		GaAs/SiC	940	10	-	400	-	-	-	20	20	3
KTIR0A21DS		GaAs/SiC	940	-	3000	-	-	-	-	80	70	

Part No.	Pin Configuration	Material	λP (nm)	I_C (μA)			$V_{CE(SAT)}$			Rise Time (μs) Typ.	Fall Time (μs) Typ.	Fig.
				$V_{CE}=5V, I_F=20mA$			IF(mA)	IC(mA)	Max.(V)			
				Min.	Typ.	Max.						

KRC011		GaAs/SiC	940	10	-	300	-	-	-	20	20	4
--------	--	----------	-----	----	---	-----	---	---	---	----	----	---

Fig.1

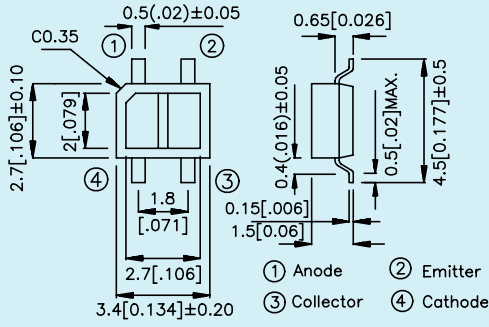

Fig.3

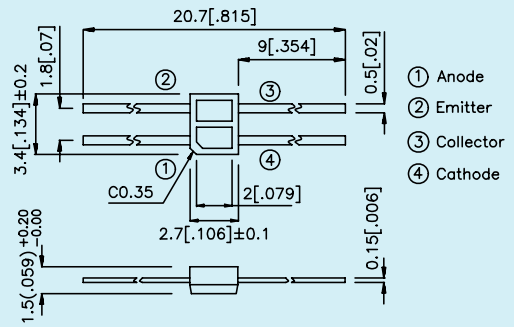

Fig.2

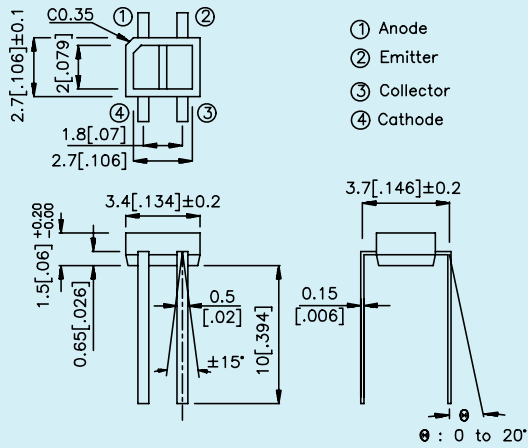
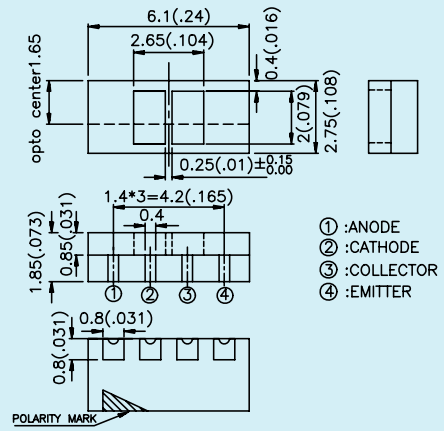
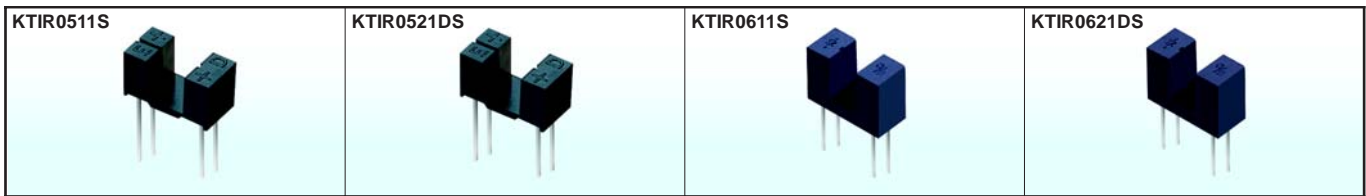

Fig.4



NOTES:

1. All dimensions are in millimeters(inches).
2. Tolerance is $\pm 0.25\text{mm}(0.01")$ unless otherwise noted.



Part No.	Pin Configuration	Material	λ P (nm)	CTR			$V_{CE(SAT)}$			Rise Time (μ s) Typ.	Fall Time (μ s) Typ.	Fig.
				IF(mA)	V_{CE} (V)	Typ.(%)	IF(mA)	IC(mA)	Max.(V)			
KTIR0511S		GaAs/SiC	940	20	5	10	40	1	0.4	5	4	6
KTIR0521DS		GaAs/SiC	940	1	2	180	2	1	1	90	80	7
KTIR0611S		GaAs/SiC	940	20	5	14	40	1	0.4	5	4	8
KTIR0621DS		GaAs/SiC	940	1	2	200	2	1	1	90	80	9

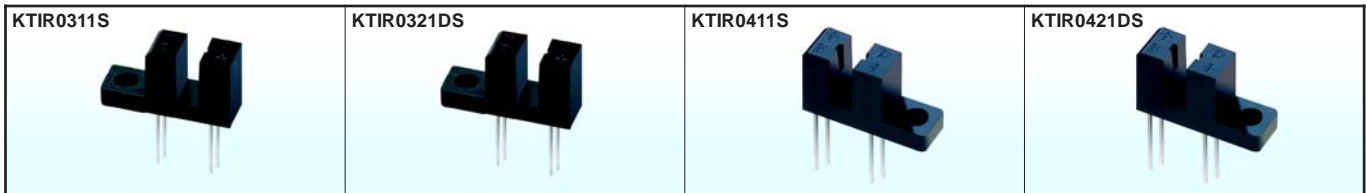

Part No.	Pin Configuration	Material	λ P (nm)	CTR			$V_{CE(SAT)}$			Rise Time (μ s) Typ.	Fall Time (μ s) Typ.	Fig.
				IF(mA)	V_{CE} (V)	Typ.(%)	IF(mA)	IC(mA)	Max.(V)			
KTIR0311S		GaAs/SiC	940	20	5	38	40	1	0.4	5	4	10
KTIR0321DS		GaAs/SiC	940	1	2	650	2	1	1	90	80	11
KTIR0411S		GaAs/SiC	940	20	5	38	40	1	0.4	5	4	12
KTIR0421DS		GaAs/SiC	940	1	2	650	2	1	1	90	80	13

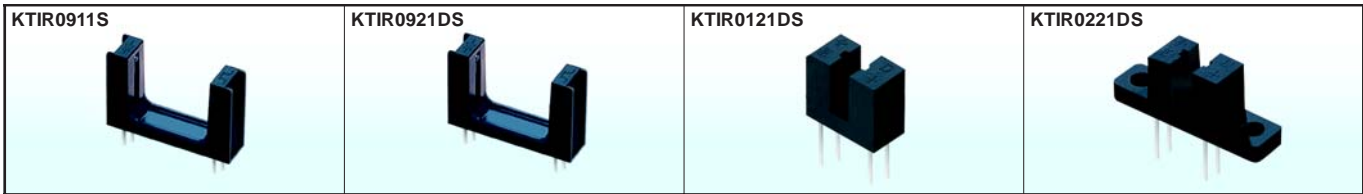

Part No.	Pin Configuration	Material	λ P (nm)	CTR			$V_{CE(SAT)}$			Rise Time (μ s) Typ.	Fall Time (μ s) Typ.	Fig.
				IF(mA)	V_{CE} (V)	Typ.(%)	IF(mA)	IC(mA)	Max.(V)			
KTIR0911S		GaAs/SiC	940	20	5	9.5	40	1	0.4	5	4	14
KTIR0921DS		GaAs/SiC	940	1	2	120	2	1	1	90	80	15
KTIR0121DS		GaAs/SiC	940	1	2	600	2	1	1	90	80	16
KTIR0221DS		GaAs/SiC	940	1	2	600	2	1	1	90	80	17

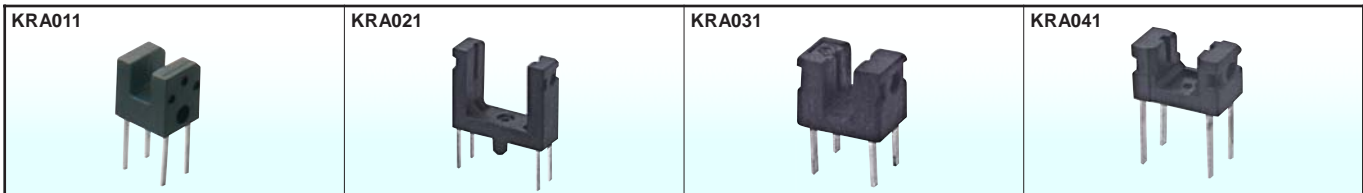

Part No.	Pin Configuration	Material	λ P (nm)	CTR			$V_{CE(SAT)}$			Rise Time (μ s) Typ.	Fall Time (μ s) Typ.	Fig.
				IF(mA)	V_{CE} (V)	Typ.(%)	IF(mA)	IC(mA)	Max.(V)			
KRA011		GaAs/SiC	940	5	5	8	10	0.04	0.4	50	50	18
KRA021		GaAs/SiC	940	10	2	18	20	0.25	0.4	15	15	19
KRA031		GaAs/SiC	940	5	2	10	10	0.15	0.4	15	15	20
KRA041		GaAs/SiC	940	5	2	6	10	0.4	0.4	15	15	21



Part No.	Pin Configuration	Material	λ P (nm)	CTR			$V_{CE(SAT)}$			Rise Time (μ s) Typ.	Fall Time (μ s) Typ.	Fig.
				IF(mA)	V_{CE} (V)	Typ.(%)	IF(mA)	IC(mA)	Max.(V)			
KRB011		GaAs/SiC	940	5	5	3	20	0.05	0.4	8	10	22
KRB021		GaAs/SiC	940	5	5	3	20	0.05	0.4	8	10	23
KRB031		GaAs/SiC	940	5	5	3	20	0.05	0.4	8	10	24

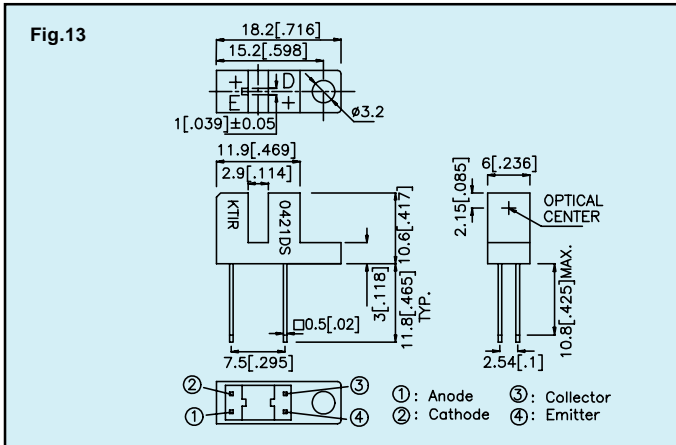
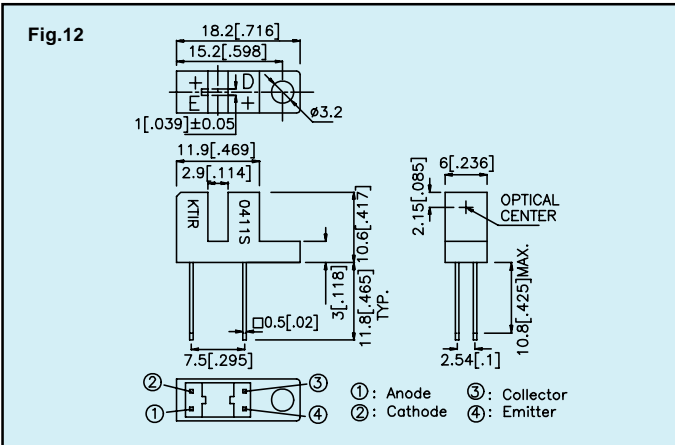
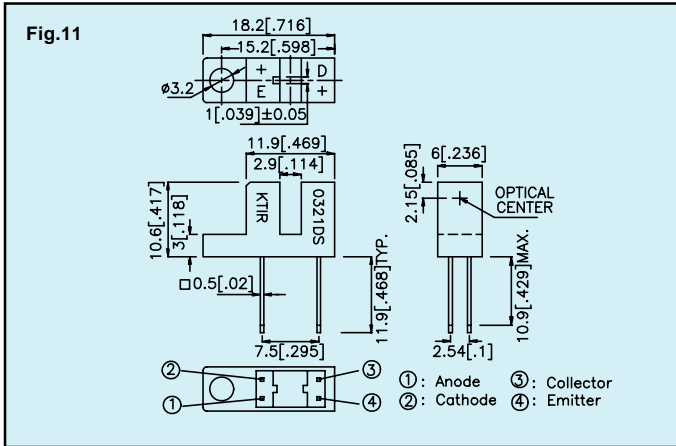
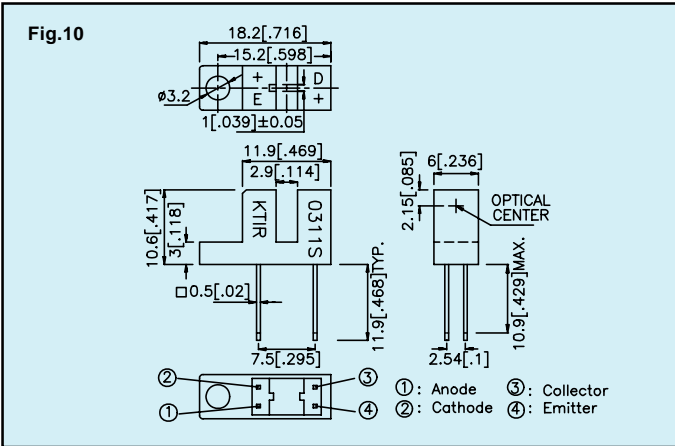
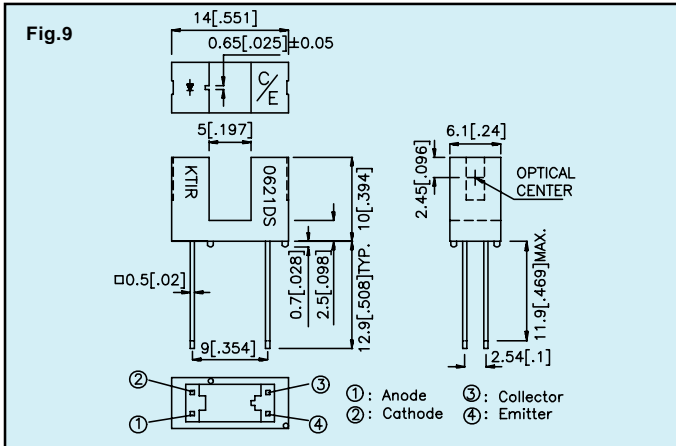
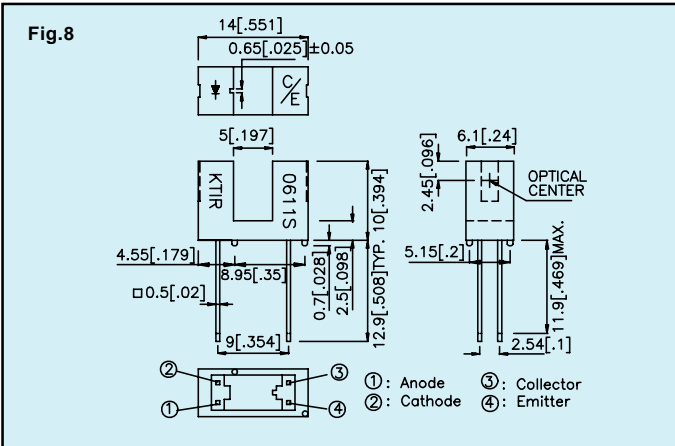
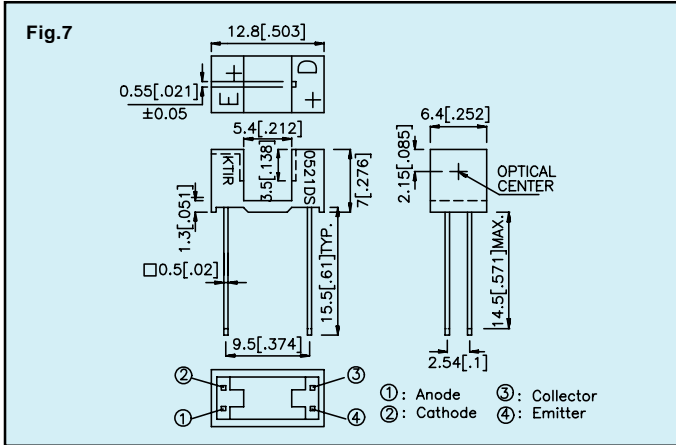
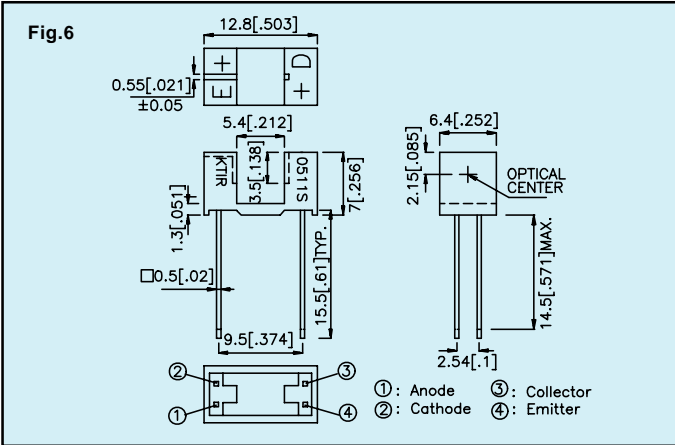

NOTES:
 1. All dimensions are in millimeters (inches).
 2. Tolerance is ±0.25mm (0.01") unless otherwise noted.

Fig.14

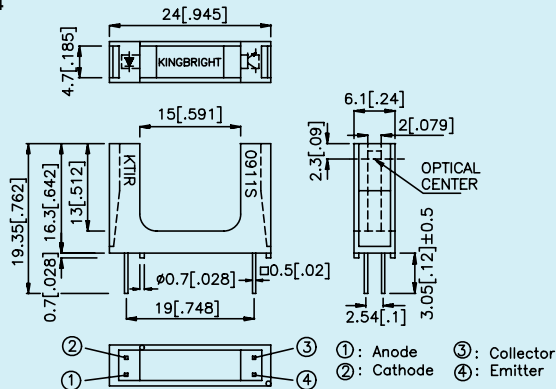

Fig.15

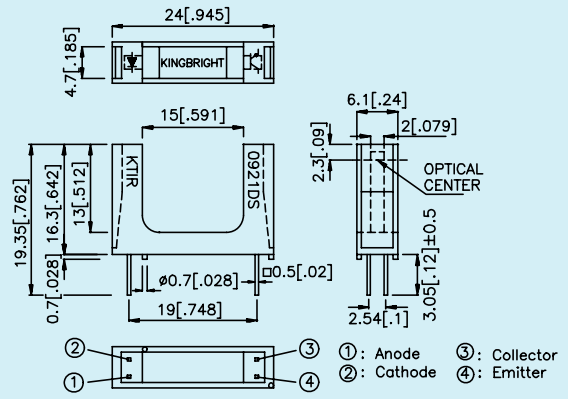

Fig.16

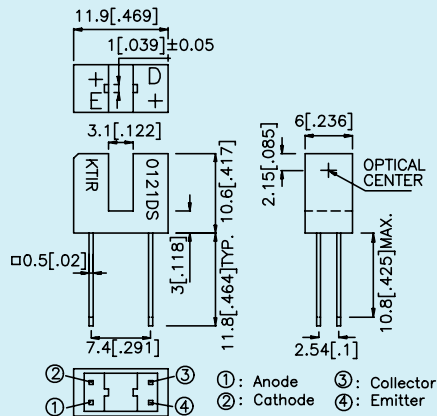

Fig.17

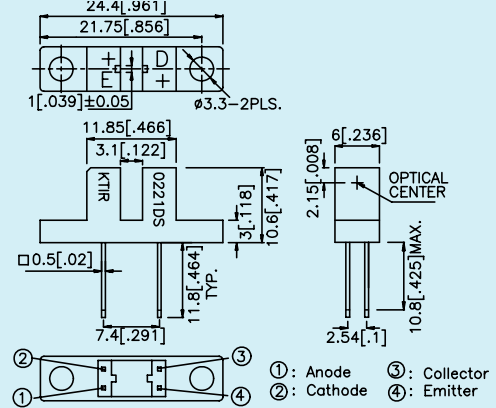

Fig.18

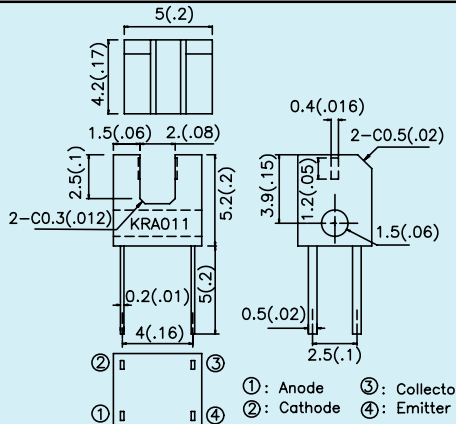

Fig.19

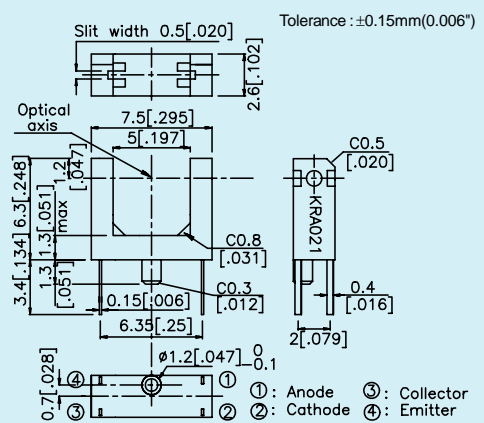

Fig.20

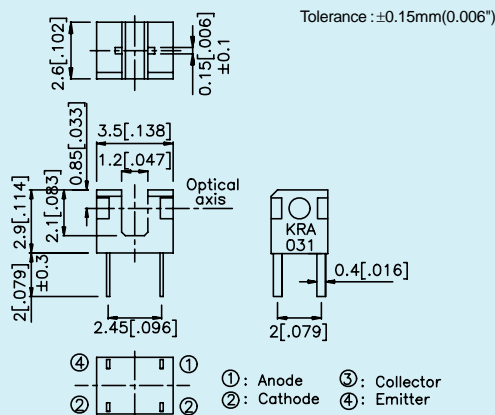
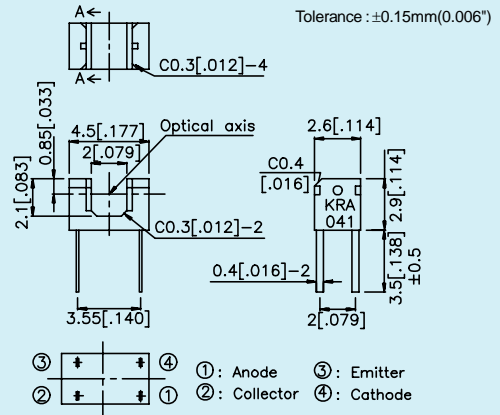
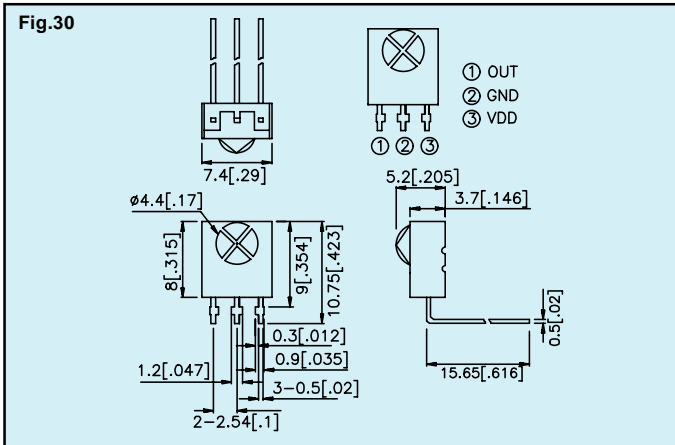
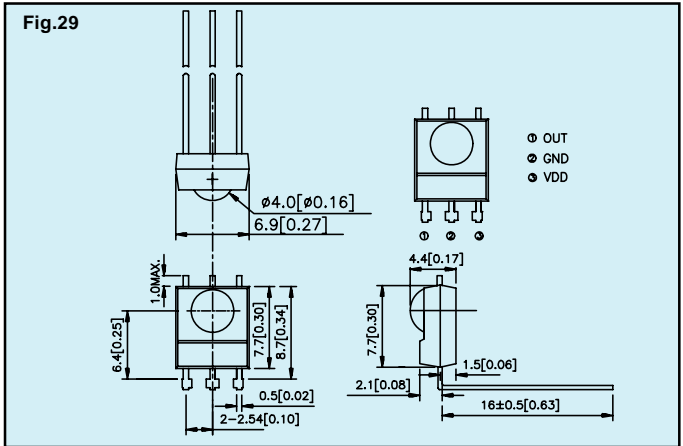
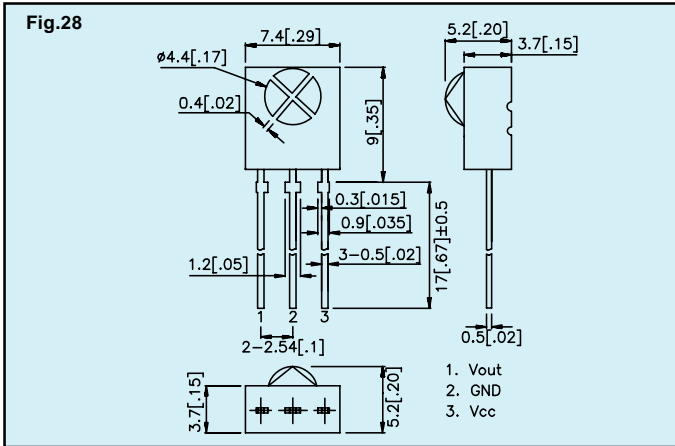
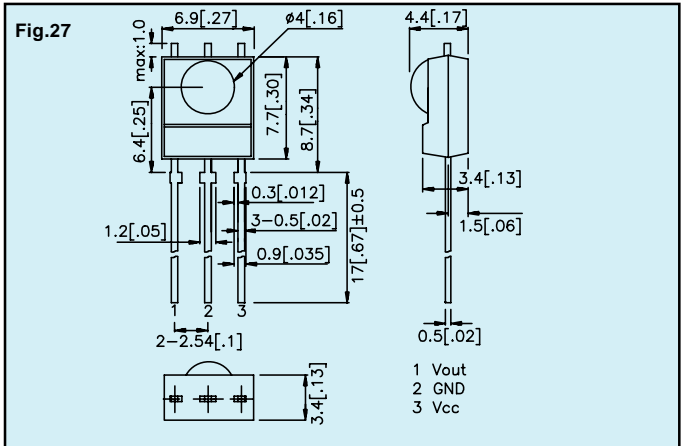
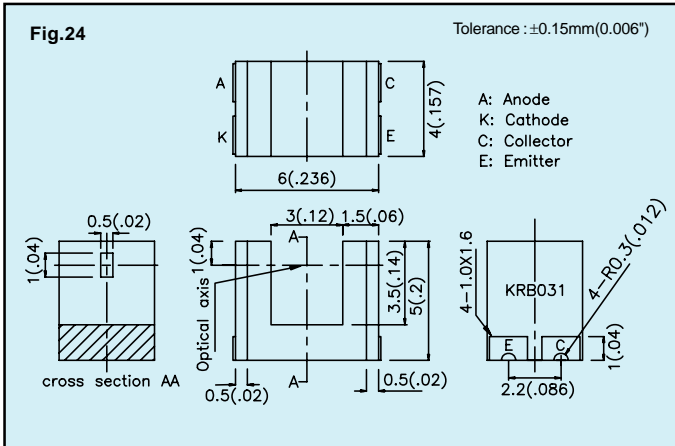
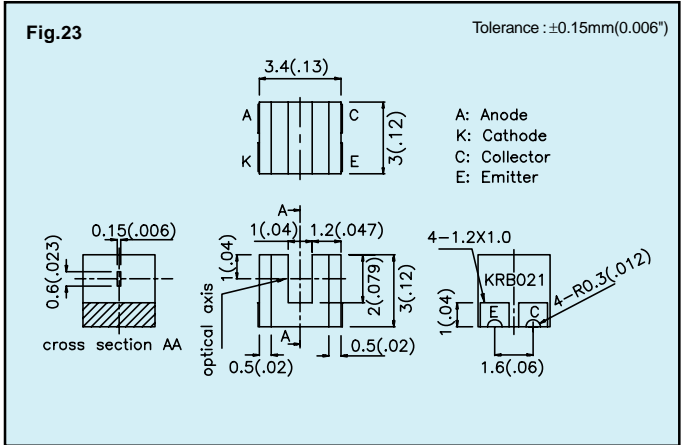
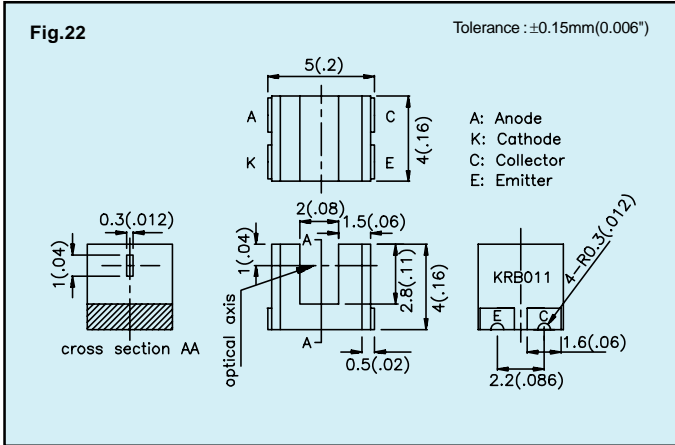

Fig.21



NOTES:

1. All dimensions are in millimeters(inches).
2. Tolerance is $\pm 0.25\text{mm}(0.01")$ unless otherwise noted.



NOTES:
1. All dimensions are in millimeters(inches).
2. Tolerance is ±0.25mm(0.01") unless otherwise noted.

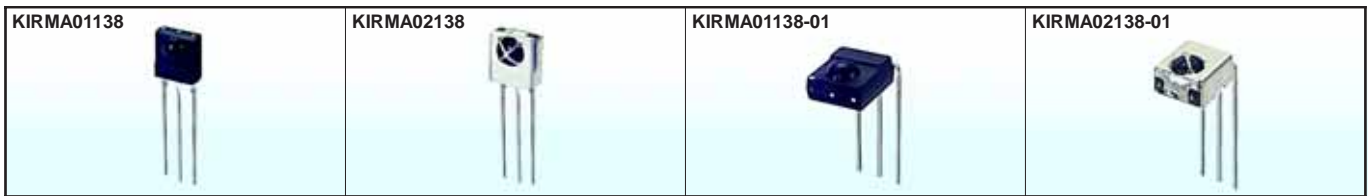

Part No.	Center Frequency	Supply Voltage		Supply Current	Reception Distance		Half Angle	Fig.
	Fc (kHz) Typ.	V _{cc} (V)		I _{cc} (mA) Typ.	L ₀ (m) Min.	L ₄₅ (m) Min.	θ (°) Typ.	
		Min.	Max.					
KIRMA01138	38	2.5	5.5	0.8	14	6	+/-45	27
KIRMA02138	38	2.5	5.5	0.8	14	6	+/-45	28
KIRMA01138-01	38	2.5	5.5	0.8	14	6	+/-45	29
KIRMA02138-01	38	2.5	5.5	0.8	14	6	+/-45	30